



PRODUCT CATALOG (15KV/33KV) OIL IMMERSED TRANSFORMER

version 2024-11EN

IEC 60076 Series;
GB 20052-2020, GB 1094-1996,
GB / T 6451-2008, GB / TT7597-2007,



HENGFENGYOU ELECTRIC GROUP

Smart Electric Global Service provider

Make life better!



www.hengfengyou.com

CATALOGUE

▪ Company profile	01
▪ Certificate	02
▪ Product overview	03
▪ Product advantage	04
▪ Our factory	06
▪ Technical Parameter	08
▪ Quality control	11
▪ TEST	13
▪ Installation	14
▪ Service	17

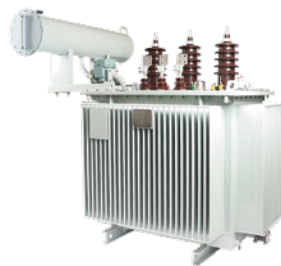

ABOUT HENGFENGYOU ELECTRIC GROUP

HENGFENGYOU ELECTRIC GROUP, is an electrical enterprise with transmission and distribution industry as its main business, integrating product research and development, manufacturing and trade. Designated suppliers for the world's top 500 enterprises. Its main products include power transformers, medium and low voltage switchgear, distribution panel, circuit breakers, transmission tower, Cable and other power distribution equipment. The group has five departments: Transformer department, Panel department, power transmission tower department, cable department and electrical engineering department. HENGFENGYOU ELECTRIC GROUP has been working hard to provide the best transmission, distribution solutions for users all over the world.

Key figures

- Since: 1990
- Revenue in 2018: 635 million (RMB)
- 550 employees and 30 Electrical Engineers
- 6 production sites in China
- 6% of revenue is invested in R &D

Power distribution solutions that drive the global energy transition

With energy demand expanding in both developed and emerging countries, the challenge for HENGFENGYOU ELECTRIC GROUP is to connect energy with people. The group's teams work as closely as possible with projects and decision makers and design and propose technical and process solutions based on global user needs.



Qingdao Hengfengyou Electrical Engineering Co., Ltd
Address: N0.638 Zhongcheng Road, Chengyang District, Qingdao City, China
Tel: +86-532--87936206
Website: <http://www.hengfengyou.com>
Sales: hfy@hengfengyou.com Service: service@hengfengyou.com



QUALIFICATION CERTIFICATION



OUR PARTNER



🔄 PRODUCT OVERVIEW

· Product Overview

- The actual measurement of the product is superior to GB and IEC standards, CB CCC KEMA SASO certification, etc
- The high reliability of operation verification in more than 50 countries and regions around the world has been sold to Cameroon, Angola, Uganda, Rwanda, Zambia, Ethiopia, and other countries and regions, with a cumulative export of 12598 sets
- Executive Standards: IEC 60076 Series, IEC 6013, IEC 60214-1, IEC 60296; GB 1094-1996, GB / T 6451-2008, GB / TT7597-2007, etc



Oil Immersed Transformer



PRODUCT ADVANTAGE

Leading technology

- High voltage copper tape winding technology to improve lightning resistance
- Low voltage copper foil winding technology, high quality A grade insulation material insulation
- Small magnetic leakage, high mechanical strength, short circuit resistance
- Core 45° fully inclined joint step laminated structure



OLTC Transformer

The shell

- ABB robot automatic welding, laser detection, avoid leakage, pass rate of 99.99998%
- Electrostatic spray treatment, 50 years without removing paint (coating corrosion resistance within 100h, hardness ≥ 0.4)
- Fully sealed structure, maintenance free, normal operation service life of more than 30 years

The iron core

The iron core is made of high quality cold-rolled grain oriented silicon steel sheet with mineral oxide insulation (from Baosteel and WISCO of China).

By controlling the cutting and stacking process of silicon steel sheet, the loss level, no-load current and noise can be minimized. The iron core is specially reinforced to ensure the structure of the transformer is firm during normal operation and transportation.

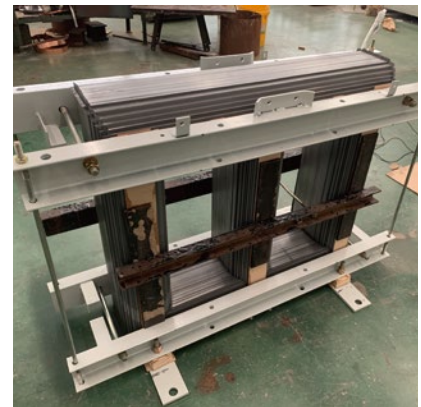
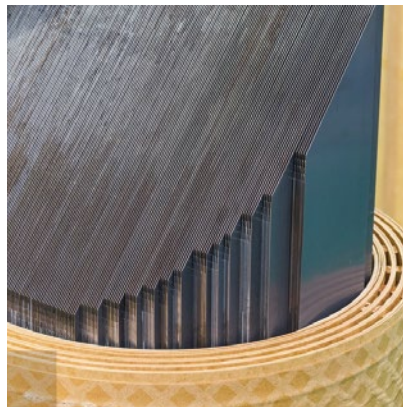

PRODUCT ADVANTAGE

Winding

The low voltage winding is made of high quality copper foil with excellent insulation resistance

High voltage winding is usually made of insulated copper wire, using hengfengyou electric patented technology

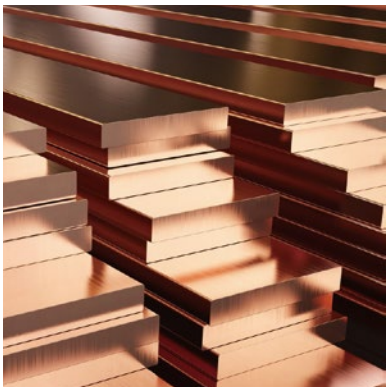
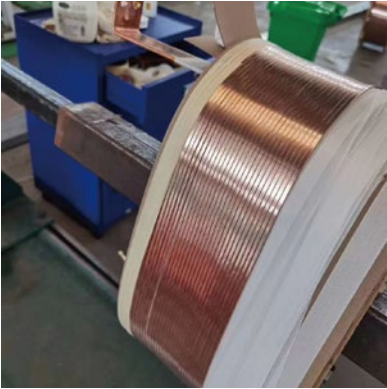

High quality material

Baosteel and WISCO produce silicon steel sheets

China's high quality oxygen free copper

CNPC (Kunlun Petroleum) High quality transformer oil (25#)

Patent technology

Thanks to hengfengyou Electric "ultra-low loss energy-saving power transformer" patent technology, can achieve 5% material savings, transformer loss than similar products in the market reduced 10-20%, more energy saving and environmental protection.



Other instructions

The low-voltage outlet terminal is a tin-plated copper bar

High voltage outlet terminals are tin-plated ring bolts

Default no-load voltage regulation (can be customized) tap switch 5 or 7 gear adjustment

Transformer above 630KVA is equipped with gas relay protection.

OUR FACTORY

Production equipment

The company mainly produces more than 300 sets of equipment, and the key equipment includes the full-automatic vacuum resin casting equipment of Hubers company, 400 / 600mm core automatic cross cutting machine, foil winding machine, the most advanced transformer kerosene vapor phase drying equipment in China, large-scale core stacking turnover platform, large scale assembly platform, etc



Silicon steel sheet crosscutting machine

Hengfengyou Electric has 22000 square meters of modern plant, with a monthly delivery capacity of up to 500 distribution transformers, and has fully passed the ISO9001, ISO14001, SA8000, BSCI and other market access standards reviewed and issued by international certification bodies. At present, the company has 10 senior engineers, 30 senior technicians and more than 300 employees, with an annual output value of US \$100 million.



FLUID FILLED DISTRIBUTION TRANSFORMER

Type of transformer	Hermetically seal liquid fille (optional conservator)
Style of transformer	Ground Mounted - Cable or busbar Connected
Choice of dielectric fluid	Mineral oil to IEC60296 (KUNLUN25#)
Ratings	25kVA up to 5000kVA (Over 5MVA, see also brochure)
Voltages	Up to 36kV (6/10/35kv 6.6/11/33kv 20/22kv 15/30kv)
Losses	GB 20052-2020 (Officially implemented on June 1, 2021)
Availability	Fast Transformer STOCK (choice of aluminium or copper windings) manufacture – 7 weeks

Standard Tank Fittings	Optional Tank Fittings
Oil level indicator	Fluid-filled conservator
Rating and diagram plate	Gas & fluid actuated relay
Off circuit tap changer	Pressure relief device
pressure relief valve	Dehydrating breather
Dial thermometer	Liquid temperature indicator
Earth terminal	Winding temperature indicator
Filling valve	Marshalling box
Drain valve	Vacuum / pressure gauge
Lifting lugs	Plain rollers and axles
Earthing terminals	

CUSTOMER-ORIENTED CREATE VALUE FOR CUSTOMERS
MAKE FRIENDS ALL OVER THE WORLD

TECHNICAL PARAMETERS

15KV Oil-immersed Transformer

Rating (kva)	High vologe (kV)	High voltage tap range (%)	Low vologe (kV)	connection symbol	No-Load Loss	Load Loss (w)	No-Load current(%)	Short current impedance(%)
50	15	±5% ±2×2.5%	0.4	Dyn11 Yyn0	130	870	2.0	4
100					200	1500	1.6	4
125					240	1800	1.5	4
160					290	2200	1.4	4
200					330	2600	1.3	4
250					400	3050	1.2	4
315					480	3650	1.1	4
400					570	4300	1.0	4.5
500					680	5150	1.0	4.5
630					810	6200	0.9	4.5
800					980	7500	0.8	4.5
1000					1150	10300	0.7	4.5

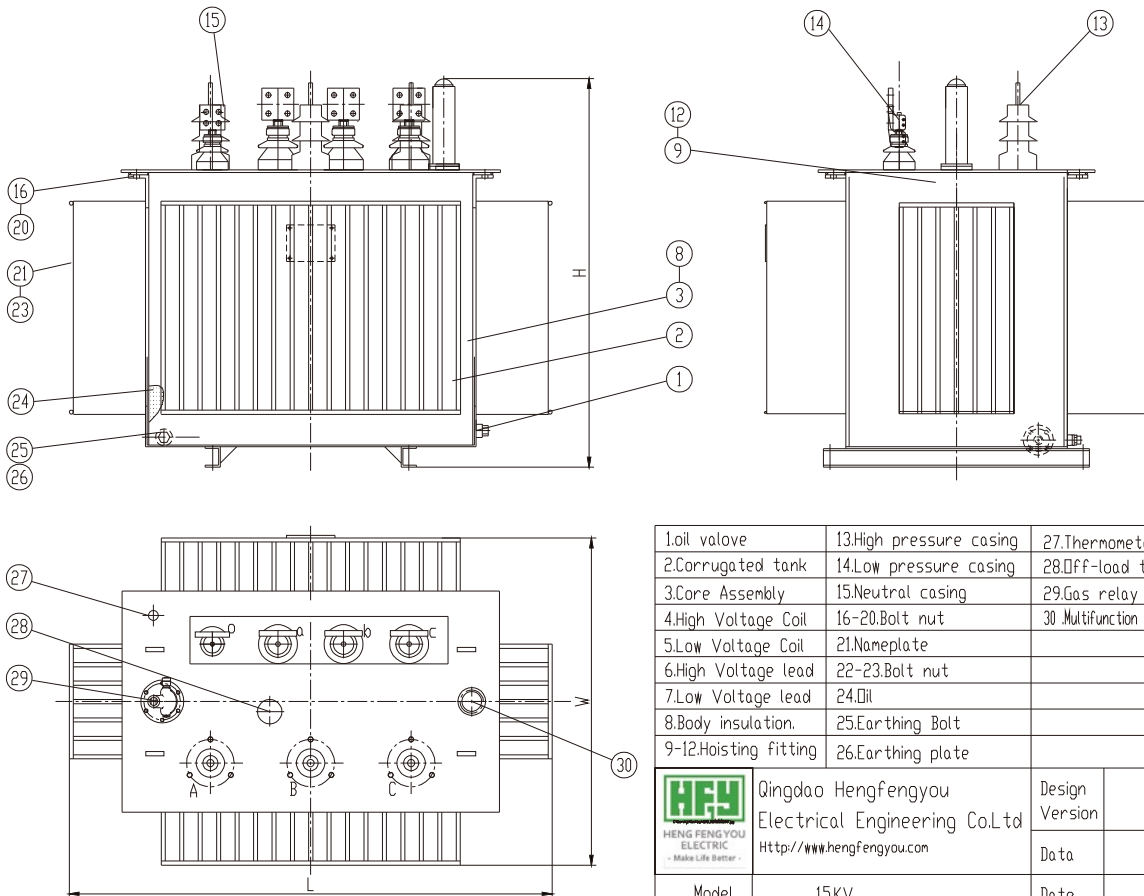

Qingdao Hengfengyou Electrical Engineering Co.Ltd
[Http://www.hengfengyou.com](http://www.hengfengyou.com)

Design
Version

Date

Model 15KV

Date

Copyright by HENGFENGYOU ELECTRIC 2020

TECHNICAL PARAMETERS

S9 33KV Oil-immersed Transformer

Rating (kva)	High vologe (kV)	High voltage tap range (%)	Low vologe (kV)	connection symbol	No-Load Loss	Load Loss (w)	No-Load current(%)	Short current impedance(%)
50	33	±5% ±2×2.5%	0.4	Dyn11 Yyn0	210	1270/1210	2.0	6.5
100					290	2120/2020	1.8	6.5
125					340	2500/2380	1.7	6.5
160					360	2970/2380	1.6	6.5
200					430	3500/3330	1.5	6.5
250					510	4160/3960	1.4	6.5
315					610	5010/4770	1.4	6.5
400					730	5050/5760	1.3	6.5
500					860	7280/6930	1.2	6.5
630					1040	8280	1.1	6.5
800					1230	9900	1.0	6.5
1000					1440	12150	1.0	6.5
1250					1760	14670	0.9	6.5
1600					2120	17550	0.8	6.5
2000					2490	20740	0.8	6.5
2500					2950	24420	0.8	6.5
3150					3510	29050	0.7	6.5
4000					4200	34940	0.7	6.5
5000					4960	41160	0.7	6.5

S11 33KV Oil-immersed Transformer

Rating (kva)	High vologe (kV)	High voltage tap range (%)	Low vologe (kV)	connection symbol	No-Load Loss	Load Loss (w)	No-Load current(%)	Short current impedance(%)
50	33	±5% ±2×2.5%	0.4	Dyn11 Yyn0	160	1200/1140	1.3	6.5
100					230	2010/1910	1.1	6.5
125					270	2370/2260	1.1	6.5
160					280	2820/2680	1.0	6.5
200					340	3320/3160	1.0	6.5
250					400	3950/3760	0.95	6.5
315					480	4750/4530	0.95	6.5
400					580	5740/5470	0.85	6.5
500					680	6910/6580	0.85	6.5
630					830	7860	0.65	6.5
800					980	9400	0.65	6.5
1000					1150	11500	0.65	6.5
1250					1400	13900	0.6	6.5
1600					1690	16600	0.6	6.5
2000					1990	19700	0.55	6.5
2500					2360	23200	0.55	6.5
3150					2810	27600	0.5	6.5
4000					3360	33000	0.5	6.5
5000					3970	39100	0.5	6.5

TECHNICAL PARAMETERS

S13 33KV Oil-immersed Transformer

Rating (kva)	High volage (kV)	High voltage tap range (%)	Low volage (kV)	connection symbol	No-Load Loss	Load Loss (w)	No-Load current(%)	Short current impedance(%)
50	33	±5% ±2×2.5%	0.4	Dyn11 Yyn0	130	1200/1140	1.3	6.5
100					185	2010/1910	1.1	6.5
125					215	2370/2260	1.1	6.5
160					225	2820/2680	1.0	6.5
200					270	3320/3160	1.0	6.5
250					320	3950/3760	0.95	6.5
315					385	4750/4530	0.95	6.5
400					465	5740/5470	0.85	6.5
500					545	6910/6580	0.85	6.5
630					665	7860	0.65	6.5
800					785	9400	0.65	6.5
1000					920	11500	0.65	6.5
1250					1120	13900	0.6	6.5
1600					1350	16600	0.6	6.5
2000					1590	19700	0.55	6.5
2500					1890	23200	0.55	6.5
3150					2250	27600	0.5	6.5
4000					2690	33000	0.5	6.5
5000					3180	39100	0.5	6.5

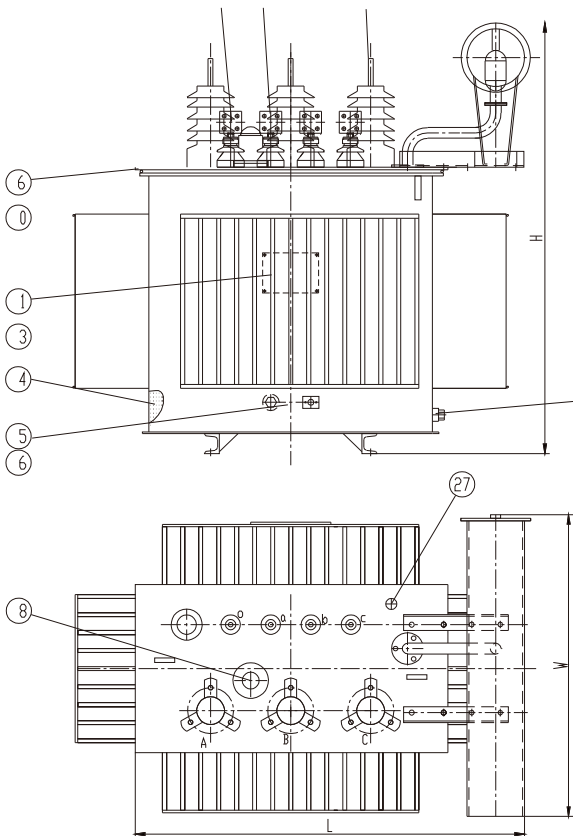

1.Oil valve	13.High pressure casing	28.Off-load tap-changer
2.Corrugated tank	14.Low pressure casing	29.Oil Storage tank
3.Core Assembly	15.Neutral casing	
4.High Voltage Coil	16-20.Bolt nut	
5.Low Voltage Coil	21-23.Nameplate	
6.High Voltage lead	24.Oil	
7.Low Voltage lead	25.Earthing Bolt	
8.Body insulation	26.Earthing plate	
9-12.Hoisting fitting	27.Thermoneter stand	
 Qingdao Hengfengyou Electrical Engineering Co.Ltd Http://www.hengfengyou.com	Design	
	Version	
	Data	
Model	33KV	Date

Copyright by HENG FENGYOU ELECTRIC 2020

🎯 QUALITY CONTROL:

Sustainable innovative development and responsible management are the two pillars of social responsibility for Hengfengyou Electric.

- 1.HENGFENGYOU has developed strict workflow and ISO standards to ensure the provision of first-class distribution transformers and the best service to customers.
- 2.The HENGFENGYOU team collaborates within the team to develop and produce distribution transformer solutions that meet all customer needs.
- 3.Our equipment is designed and researched by R&D services based on the electrical standards of each country, and helps manage your distribution network for optimal efficiency.
- 4.HENGFENGYOU's state-of-the-art transformer production workshop and equipment will produce high-quality products according to your requirements and specifications.
- 5.HENGFENGYOU has a certified quality control laboratory where transformer products undergo factory testing to ensure the reliability and optimal lifespan of our products.

Our Team:

1. Our electrical engineer has more than 10 years of working experience
- Our workshop workers are all skilled industrial workers who have received three months 'pre-job training
3. Our sales team has been extensively trained by management consultants to provide professional solutions for customers
4. Our technical team can provide customers with 24-hour technical support world wide
5. Our customer service team ensures that orders are delivered on time.
- 6.professional after-sales service technicians can ensure the correct commissioning and operation of the transformer.

LOGISTICS SHIPMENT



QUALITY CONTROL:

We have established strict SQA working procedures and ISO standards in the development, production, sales and after-sales of electrical products, so as to provide customers with first-class products and the best service.

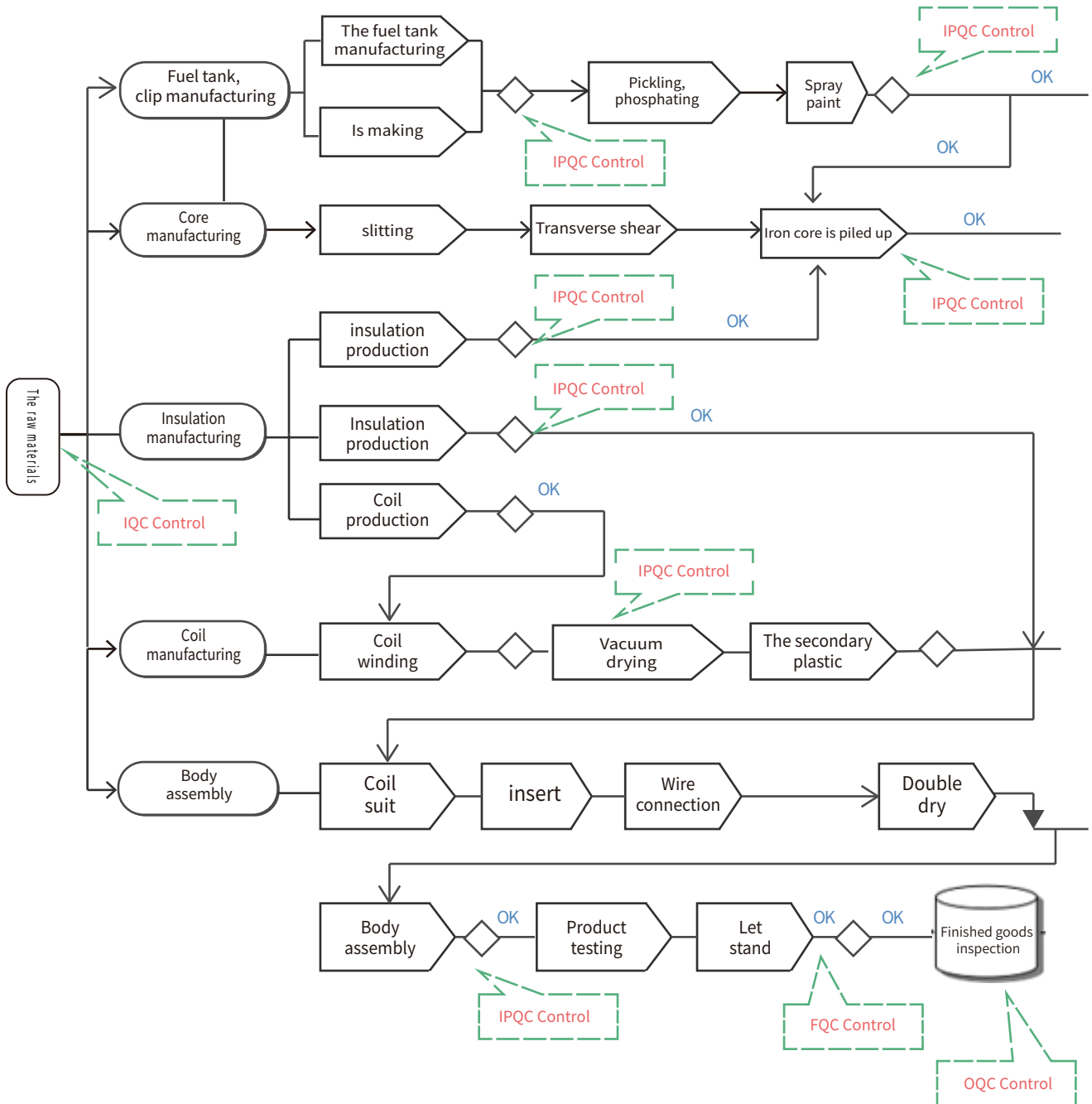

SQA MANAGEMENT OF OIL IMMERSSED TRANSFORMER

TEST



Comprehensive experimental platform for power transformer

Delivery test (or routine test)

These tests verify the electrical performance specified in the contract. And submit a formal test report.

characteristic measurement

- Winding resistance;
- Transformation ratio and vector group;
- Impedance voltage;
- Load loss;
- No load loss and no-load current.

insulation test:

- Power frequency withstand voltage test- Inductive voltage withstand test.
- Partial discharge measurement ensures that the expected service life of transformer less than 5pc is closely related to the initial partial discharge level measured during manufacturing.

Special test

These tests will be arranged at customer's request at customer's expense.

Short circuit test

These tests were carried out on a special test bench in accordance with IEC 60076-5.

A total of three tests were performed on each transformer column, each lasting 0.5 seconds.

Noise level measurement

- Noise level measurement is part of a special test.

- Transformer noise is mainly caused by magne

tostriction of magnetic circuit.

- Noise levels can be expressed in two ways:

Sound pressure level L_p , measured in accordance with IEC 551 at 1m from the transformer in no-load operation



Noise testing chamber



Transformer test

INSTALLATION

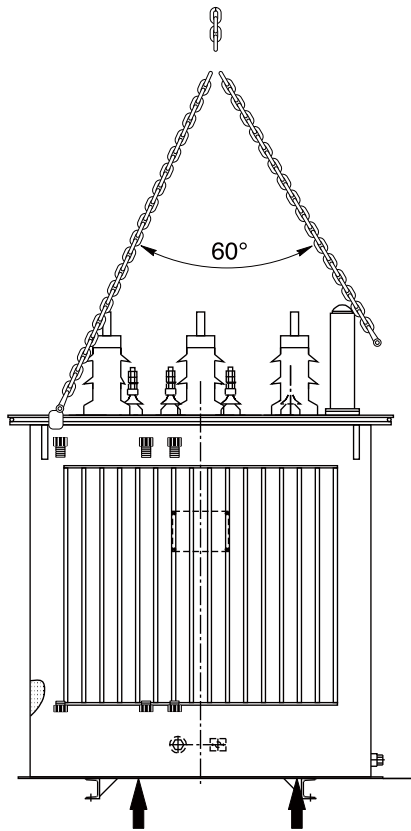

Forklift lifting device

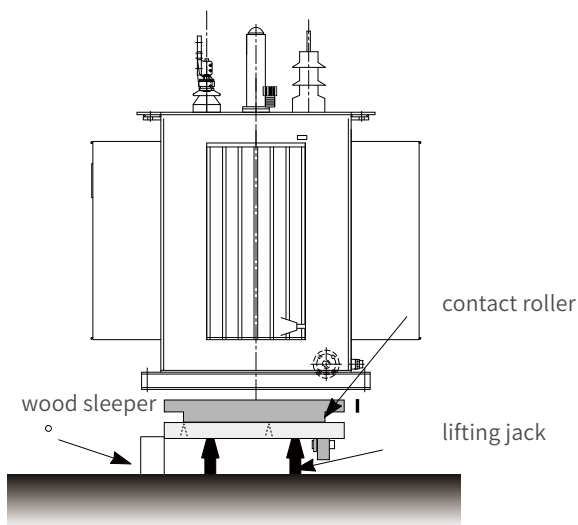

carry

Use the 4 lifting lugs of the transformer (it must be lifted vertically, not obliquely); For the transformer with 2 lifting lugs in the center of the top of the shell, use 2 lifting lugs. The included angle formed by the sling shall not be greater than 60°.

First, check the forklift's forking capacity. If appropriate, the fork arm shall be inserted into the base channel after removing the roller.

The transformer with or without enclosure shall be hauled from the base. For this purpose, holes with a diameter of 27mm are opened on each side of the base. It can be dragged from two directions: the axial direction of the base and the direction perpendicular to this axis.

storage

Hengfengyou transformer shall avoid being polluted by dripping water and sand dust (such as masonry and sand blasting) during storage. If hengfengyou transformer is supplied with a plastic cover, it shall be covered on the equipment during storage. Hengfengyou transformer can be stored in an environment with a minimum room temperature of - 25 ° C and a maximum room temperature of 50 ° C.

No gas or conductive dust that seriously affects the insulation of the transformer; No explosion hazard, no corrosion of electrical components

© INSTALLATION

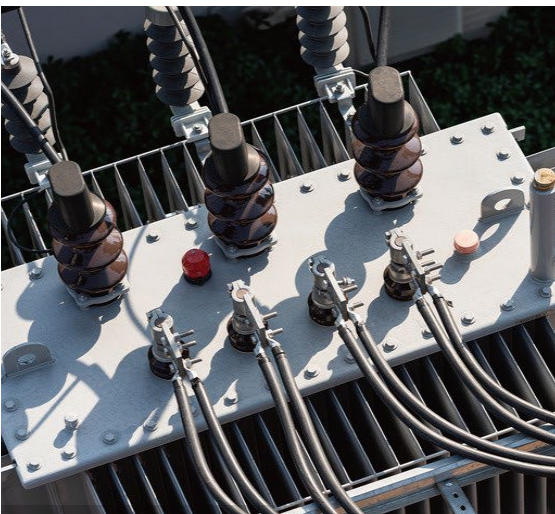

INSTALLATION SITE

· The transformer shall be installed in a dry, flat place where water is not easy to enter. The installation site shall have sufficient ventilation to ensure that all heat of the transformer can be dissipated

· No load shall be supported anywhere on the enclosure except the power supply cable of the transformer. In addition to correctly installing the connecting cable according to the relevant drawings, facilities or accessories not supplied by the manufacturer or without permission are not allowed to be installed in the shell, otherwise, the user shall bear the risk. For the transformation, connection and installation of any accessories, please consult our hengfengyou technicians.

· The embedded parts, reserved holes, etc. have been cleaned and adjusted to meet the design requirements.

· Protective mesh doors, railings, and other safety facilities are complete, and ventilation and fire protection facilities are installed.

© INSTALLATION

INSPECTION BEFORE OPERATION

1. The transformer body and accessories are free from defects, oil leakage, and kept clean.
2. Is the nameplate, voltage level, wiring group, tap position and operation mode, cooling conditions, etc. of the transformer consistent with the actual situation.
3. Whether the connection of the incoming and outgoing lines is firm and reliable, whether the phase color of the transformer casing is correct, and whether the transformer casing is reliably grounded.
4. The tap position of the transformer is in the normal voltage range.
5. Is the valve between the oil conservator and the gas relay open; Whether the oil level and color of the oil level gauge are normal; Is there any gas in the gas relay protector.
6. Check whether the transformer respirator is unobstructed and whether the silicone of the moisture absorber is ineffective and discolored.
7. Is the pressure relief valve blocked and functioning properly.
8. Measure the insulation resistance of the transformer winding and bushing with a megohmmeter, and the insulation resistance value should not be less than 70% of the product's factory test value.



INSPECTION IN OPERATION

Under normal use and environmental conditions, check the transformer once a year, dust around the transformer and accessories, and fasten lead terminals, pins, grounding screws, connecting bus screws, etc.

🔄 PRE-SALE SERVICE:

1. ISO certified excellent Manufacturer
2. Third-party authoritative certifications: CE, CB, UL, CSA etc
3. Flexible payment: T/T, LC,
4. Sufficient inventory, fast delivery time and long validity of the price
5. The whole process of picture tracking can be realized in production and transportation
6. Experienced professional sales team and a strong technical team
7. Sincerely invite customers to visit the company for guidance

🔄 AFTER-SALES SERVICE:

1. If there is any quality problem after receiving the goods, you can return the goods free of charge or ship new products
2. We provide our customers with a 1-year product warranty
3. Provide 24-hour, 365-day technical guidance worldwide
4. The VIP customers enjoy our promotional activity
trained by management consultants, is able to provide professional solutions for customers.
4. Our technical team is ready for 24-hour technical support worldwide.
5. Our customer service team ensures on time delivery.



Call Us For Details



HENG FENGYOU[®]

· Make Life Better ·

智能电气全球服务提供商, 让生活更美好

SMART ELECTRIC GLOBAL SERVICE PROVIDER, MAKE LIFE BETTER

QINGDAO HENGFENGYOU ELECTRICAL ENGINEERING CO., LTD

Tel: +86-532--8793 6206

WhatsApp: JACK +86 158 5325 2696 MARTIN +86 135 8926 2999

Website: <http://www.hengfengyou.com>

Email: hfy@hengfengyou.com

service@hengfengyou.com

Address: No.638 Zhongcheng Road, Chengyang District, Qingdao City, China

